

# Panasonic

## MICRO LASER DISTANCE SENSOR HG-C SERIES

Reliable detection with

**10**  $\mu\text{m}$

repeatability



# Equipped with 0-5V analog output

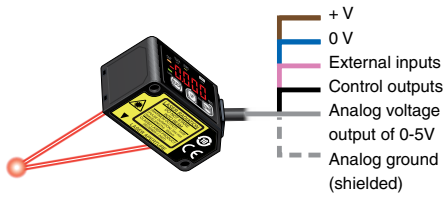

The sensor not only indicates measured values in mm, but also outputs analog voltage. The data can be used for various calculations and storage (logging) when the output is sent to a PLC + analog unit.

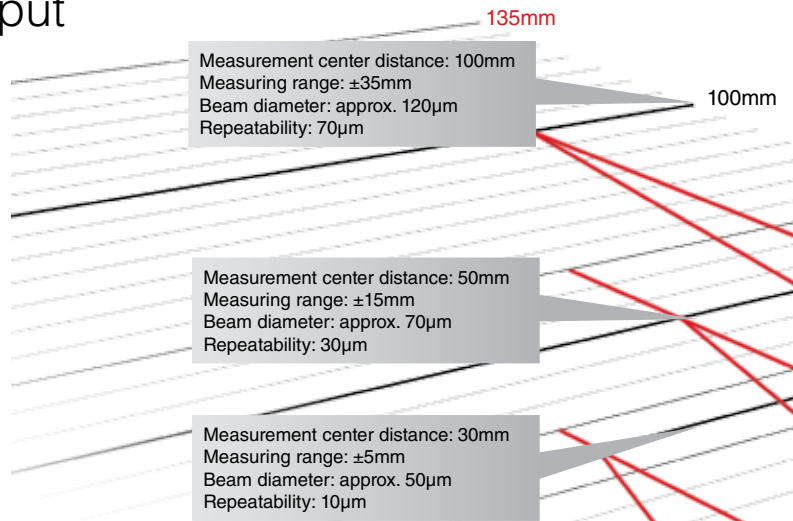

# Configurable external input

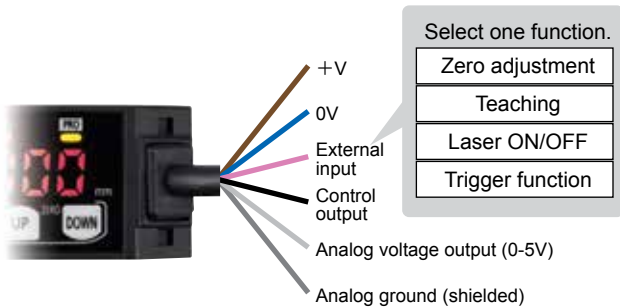

The external input can be configured to perform one of four functions: zero adjustment, teaching, Laser ON/OFF, trigger function selection.

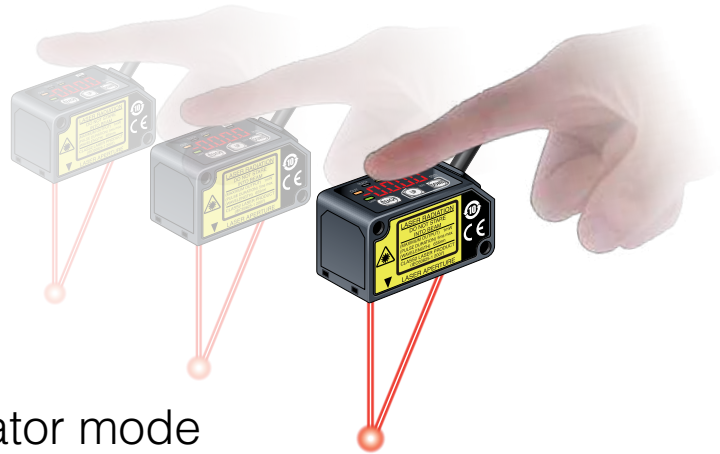

# Teaching & window comparator mode

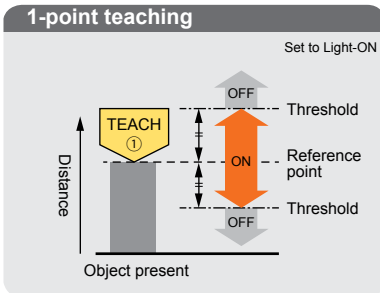

Perform 1-point teaching and the threshold range is set for the distance from the reference surface of the object to be detected.

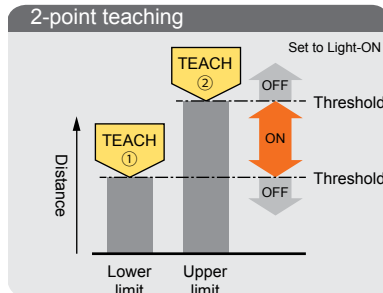

Press the button TEACH once for the lower (first point) and once for the upper limit (second point). This is useful for detecting objects at different distances.

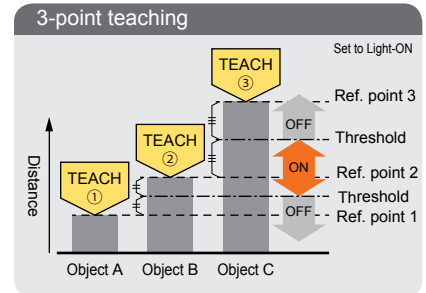

This is the method to set the threshold range by conducting the teaching at 3 points (detecting object A, B and C). After teaching, the reference points are automatically sorted in ascending order (reference point 1, 2 and 3). The thresholds are set at the midpoints between reference point 1 and 2, and 2 and 3, respectively. This is useful for detecting objects at different distances.

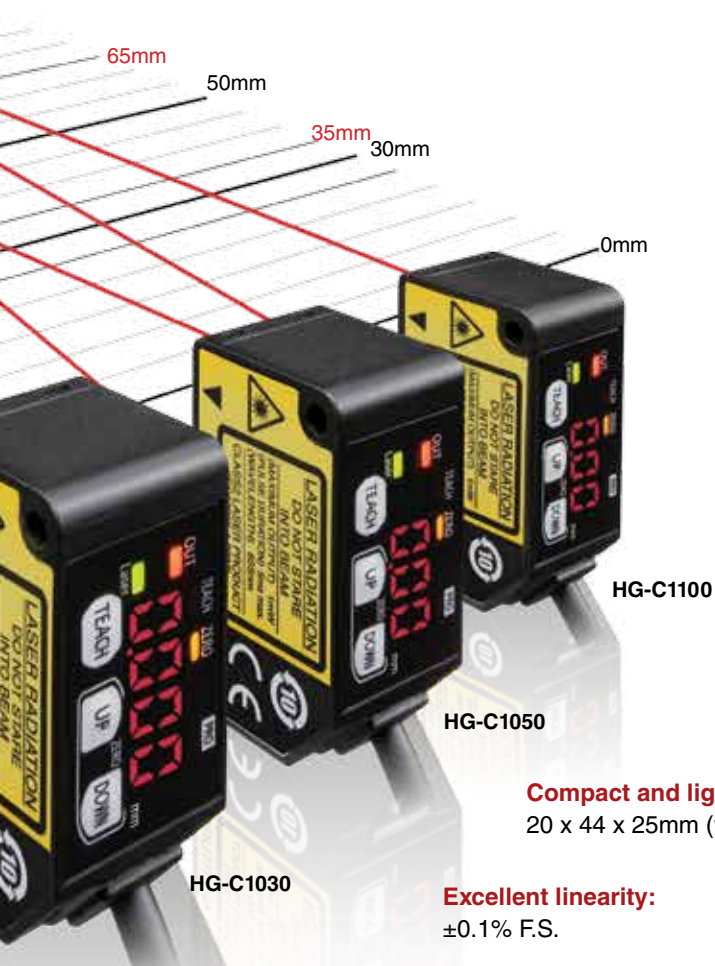

HG-C1030

HG-C1050

HG-C1100

**Compact and light weight:**  
20 x 44 x 25mm (width x height x depth)

**Excellent linearity:**  
 $\pm 0.1\%$  F.S.

**Reliable detection and overwhelmingly stable:**  
Repeatability of 10 $\mu$ m

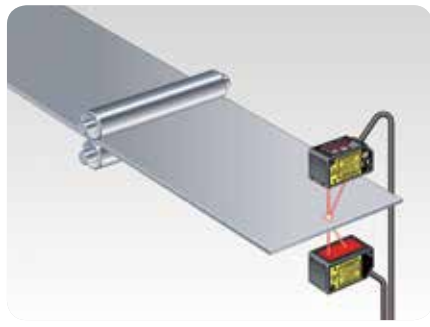

Measuring the thickness of a panel



Controlling the dispenser head height

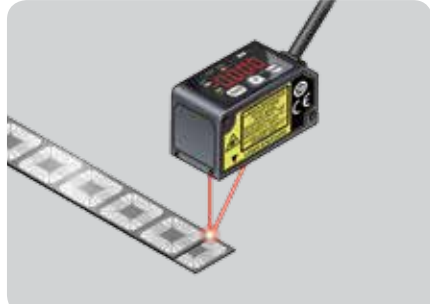

Checking for overlapped lead frames



Measuring the hoop slack



Checking for presence of O ring



Controlling the height of a robot

# Specifications

NPN output	HG-C1030	HG-C1050	HG-C1100
PNP output	HG-C1030-P	HG-C1050-P	HG-C1100-P
Applicable standards	Conforming to EMC Directive and FDA Standard		
Measurement center distance	30mm	50mm	100mm
Measuring range	±5mm	±15mm	±35mm
Repeatability	10µm	30µm	70µm
Linearity	±0.1% F.S.		
Beam diameter	Approx. 50µm	Approx. 70µm	Approx. 120µm
Supply voltage	12 to 24V DC ±10% including ripple max. 10% (P-P)		
Control output	PNP or NPN open-collector transistor		
Output operation	Either Light-ON or Dark-ON		
Short-circuit protection	Incorporated (auto-reset)		
Analog output	Voltage output: 0 to 5V (at alarm: +5.2V) Output impedance: 100Ω		
Response time	Switchable between high speed (1.5ms), standard (5ms), and high precision (10ms)		
Degree of protection	IP67 (IEC)		
Ambient temperature	-10 to +45°C (no dew condensation or icing allowed), storage: -20 to +60°C		
Ambient humidity	35 to 85% RH, storage: 35 to 85% RH		
Ambient illumination	3000lx max. (illumination level of light receiving surface under incandescent light)		
Cable	5-core cable, 2m long		
Material	Casing: aluminum die-cast, front cover: acrylic		

You would like to receive a feasibility study or an offer?  
Please contact us:

## Panasonic Electric Works Europe AG

Rudolf-Diesel-Ring 2 • 83607 Holzkirchen  
Tel.: +49 (0) 8024 6 48-0  
Fax: +49 (0) 8024 6 48-111  
E-Mail: [info.peweu@eu.panasonic.com](mailto:info.peweu@eu.panasonic.com)  
[www.panasonic-electric-works.com](http://www.panasonic-electric-works.com)